

## شكراً لتحميلك هذا الملف من موقع المناهج الإماراتية



## حل تجميعة أسئلة وفق الهيكل الوزاري بريدج

[موقع المناهج](#) ← [المناهج الإماراتية](#) ← [الصف الحادي عشر العام](#) ← [رياضيات](#) ← [الفصل الأول](#) ← [الملف](#)

تاريخ نشر الملف على موقع المناهج: 05:23:02 2023-11-07

## التواصل الاجتماعي بحسب الصف الحادي عشر العام



## روابط مواد الصف الحادي عشر العام على تلغرام

[الرياضيات](#)

[اللغة الانجليزية](#)

[اللغة العربية](#)

[التربية الاسلامية](#)

## المزيد من الملفات بحسب الصف الحادي عشر العام والمادة رياضيات في الفصل الأول

<a href="#">نموذج الهيكل الوزاري الحديد بريدج</a>	1
<a href="#">حل أسئلة الامتحان النهائي</a>	2
<a href="#">إجابات تجميعة أسئلة وفق الهيكل الوزاري</a>	3
<a href="#">نموذج أسئلة امتحان وفق الهيكل الوزاري</a>	4
<a href="#">نموذج الهيكل الوزاري الفصل الأول</a>	5

هيكل 11 عام بريدج 2024

الأسئلة مع الإجابات

لا تنسوني ووالدي من صالح دعائكم



Use the order of operations to evaluate algebraic expressions

Evaluate each expression if  $a = -2$ ,  $b = 3$ , and  $c = 4.2$ .

1.  $a - 2b + 3c$  **4.6**

2.  $2a + (b + 3)^2$  **32**

3.  $a + 3[b^2 - (a + c)]$  **18.4**

4.  $5c - 2[(b - a) + c]$  **2.6**

5.  $4(2a + 3b) - 2c$  **11.6**

6.  $\frac{a^2 + 4c}{3b + 2a}$  **4.16**

7.  $\frac{b^3 + ac}{ab + 2bc}$  **0.96875**

8.  $\frac{3b + 2a}{5 - c}$  **6.25**

9.  $\frac{3a - 2c}{4ab}$  **0.6**

Translate verbal expressions into algebraic expressions and vice versa

Write an algebraic expression to represent each verbal expression.

22. the difference between the product of four and a number and 6  $4n - 6$

23. the product of the square of a number and 8  $8x^2$

24. fifteen less than the cube of a number  $x^3 - 15$

25. five more than the quotient of a number and 4  $\frac{x}{4} + 5$

Solve equations using the properties of equality

Solve each equation or formula for the specified variable.

45.  $E = mc^2$ , for  $m$   $m = \frac{E}{c^2}$

46.  $c(a + b) - d = f$ , for  $a$   $a = \frac{f + d}{c} - b$

47.  $z = \pi q^3 h$ , for  $h$   $h = \frac{z}{\pi q^3}$

48.  $\frac{x + y}{z} - a = b$ , for  $y$   $y = z(a + b) - x$

49.  $y = ax^2 + bx + c$ , for  $a$   $a = \frac{y - bx - c}{x^2}$

50.  $wx + yz = bc$ , for  $z$   $z = \frac{bc - wx}{y}$

**Example 1** Domain and Range

State the domain and range of each relation. Then determine whether each relation is a *function*. If it is a function, determine if it is *one-to-one*, *onto*, *both*, or *neither*.

a.  $\{(-6, -1), (-5, -9), (-3, -7), (-1, 7), (6, -9)\}$

Domain:  $\{-6, -5, -3, -1, 6\}$       Range:  $\{-9, -7, -1, 7\}$

function:      Yes, because each element of the domain is paired with one element of the range.

one-to-one:    No, because each element of the domain is not paired with a unique element of the range.

onto:            Yes, because each element of the range corresponds to an element of the domain.

b.

$x$	2	-1	-2	-1	2
$y$	-2	-1	0	1	2

Domain:  $\{-2, -1, 2\}$       Range:  $\{-2, -1, 0, 1, 2\}$

The relation is not a function because 2 is mapped to both  $-2$  and  $2$ , and  $-1$  is mapped to both  $-1$  and  $1$ .

Identify linear relations and functions.

State whether each function is a linear function. Write *yes* or *no*. Explain.

1.  $f(x) = \frac{x + 12}{5}$

1. Yes;

2.  $g(x) = \frac{7 - x}{x}$

2. No;

3.  $p(x) = 3x^2 - 4$

3. No;

4.  $q(x) = -8x - 21$

4. Yes;

Write linear equations in standard form

Find the  $x$ -intercept and the  $y$ -intercept of the graph of each equation. Then graph the equation using the intercepts. **12–15. See Chapter 2 Answer Appendix.**

12.  $y = 5x + 12$

13.  $y = 4x - 10$

14.  $2x + 3y = 12$

15.  $3x - 4y - 6 = 15$

12.  $-\frac{12}{5}; 12$

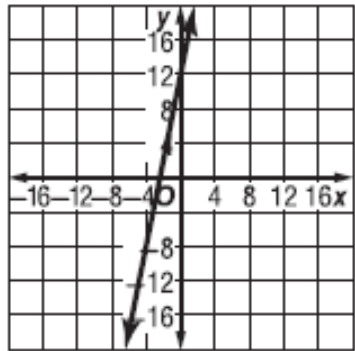

13.  $\frac{5}{2}; -10$

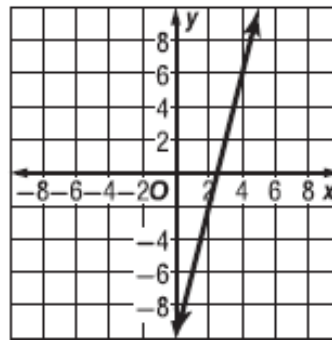

14. 6; 4

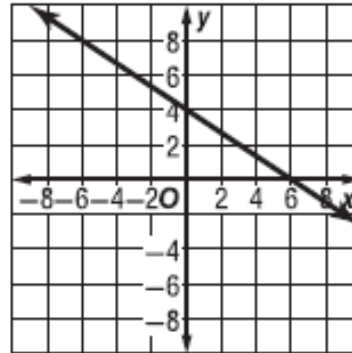

15. 7;  $-\frac{21}{4}$

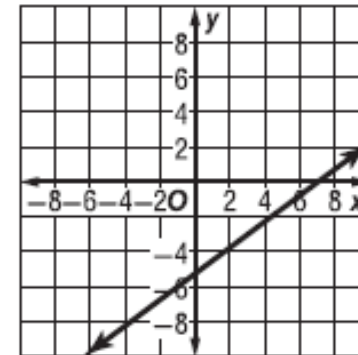



Determine the slope of a line

Find the slope of the line that passes through each pair of points. Express as a fraction in simplest form.

12.  $(-2, 11), (5, 6)$   $-\frac{5}{7}$

13.  $(-9, -11), (6, 3)$   $\frac{14}{15}$

14.  $(-1.5, 3.5), (4.5, 6)$   $\frac{5}{12}$

15.  $(-4.5, 9.5), (-1, 2.5)$   $-2$

16.  $(-8, -0.5), (-4, 5)$   $\frac{11}{8}$

17.  $(-6, -2), (-1.5, 5.5)$   $\frac{5}{3}$

Write and graph step and absolute value functions.

Graph each function. Identify the domain and range. **8–11. See Chap**

8.  $g(x) = |-3x|$

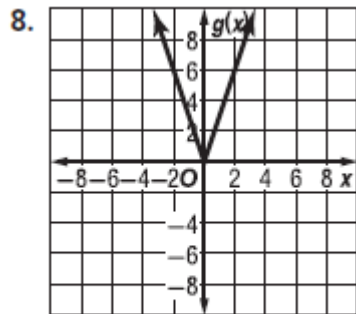

D = {all real numbers};  
R =  $\{g(x) | g(x) \geq 0\}$

9.  $f(x) = 2|x|$

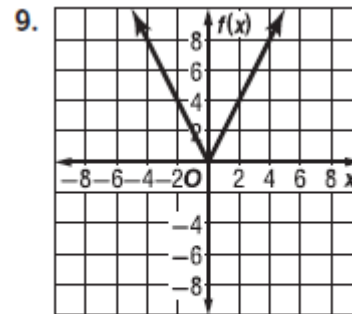

D = {all real numbers};  
R =  $\{f(x) | f(x) \geq 0\}$

10.  $h(x) = |x + 4|$

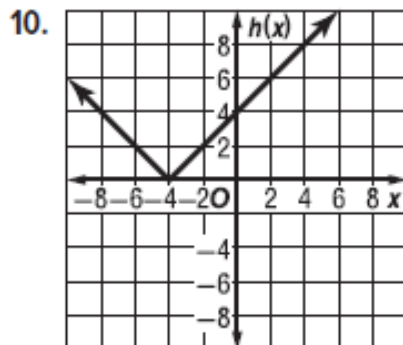

D = {all real numbers};  
R =  $\{h(x) | h(x) \geq 0\}$

11.  $s(x) = |-2x| + 6$

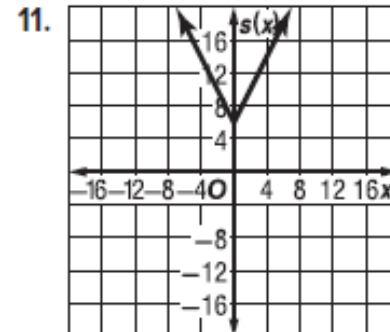

D = {all real numbers};  
R =  $\{s(x) | s(x) \geq 6\}$

Solve each system of equations by using substitution.

13.  $x + 5y = 3$

$3x - 2y = -8$   $(-2, 1)$

14.  $y = 2x - 10$

$y = -4x + 8$   $(3, -4)$

15.  $2a + 8b = -8$

$3a - 5b = 22$   $(4, -2)$

16.  $a - 3b = -22$

$4a + 2b = -4$   $(-4, 6)$

17.  $6x - 7y = 23$

$8x + 4y = 44$   $(5, 1)$

18.  $9c - 3d = -33$

$6c + 5d = -8$   $(-3, 2)$

Solve each system of equations by using elimination.

19.  $-6w - 8z = -44$

$3w + 6z = 36$   $(-2, 7)$

20.  $4x - 3y = 29$

$4x + 3y = 35$   $(8, 1)$

21.  $3a + 5b = -27$

$4a + 10b = -46$   $(-4, -3)$

22.  $8a - 3b = -11$

$5a + 2b = -3$   $(-1, 1)$

23.  $5a + 15b = -24$

$-2a - 6b = 28$  no solution

24.  $6x - 4y = 30$

$12x + 5y = -18$   $(1, -6)$

25. **MULTIPLE CHOICE** What is the solution of the linear system? **B**

$4x + 3y = 2$

$4x - 2y = 12$

A  $(8, -10)$ B  $(2, -2)$ C  $(-10, 14)$ 

D no solution

Solve systems of inequalities by graphing.

Solve each system of inequalities by graphing.

$$7. \begin{cases} x < 3 \\ y \geq -4 \end{cases}$$

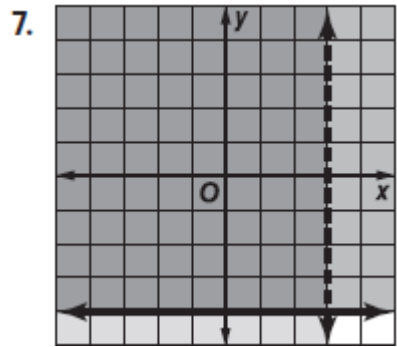

$$8. \begin{cases} y > 3x - 5 \\ y \leq 4 \end{cases}$$

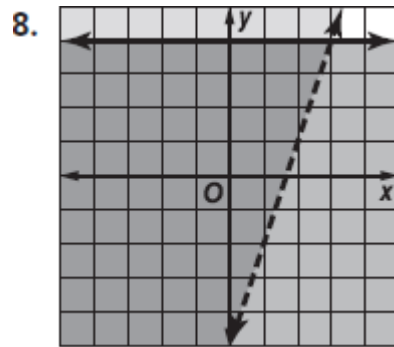

$$9. \begin{cases} y < -3x + 4 \\ 3y + x > -6 \end{cases}$$

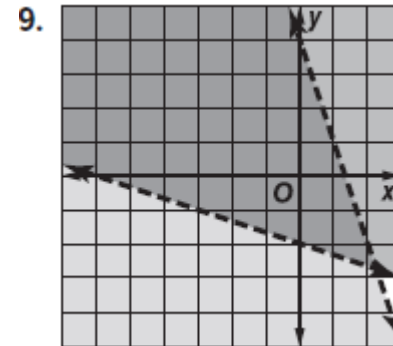

$$10. \begin{cases} y \geq 0 \\ y < x \end{cases}$$

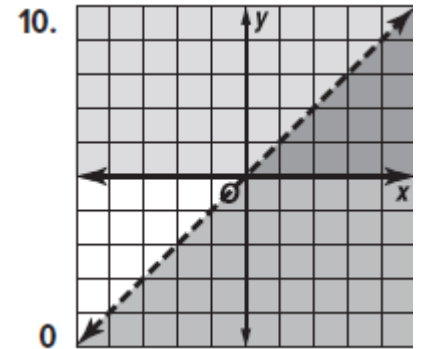

$$11. \begin{cases} 6x - 2y \geq 12 \\ 3x + 4y > 12 \end{cases}$$

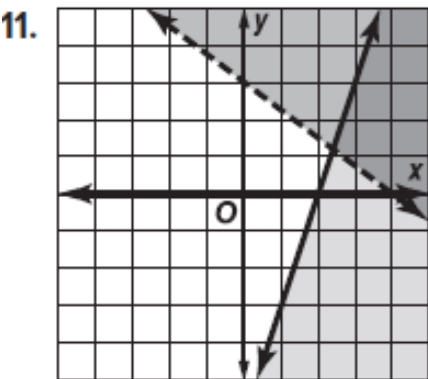

$$12. \begin{cases} -8x > -2y - 1 \\ -4y \geq 2x - 5 \end{cases}$$

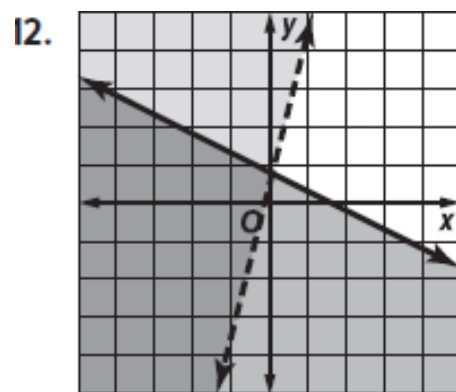

$$13. \begin{cases} 5y < 2x + 10 \\ y - 4x > 8 \end{cases}$$

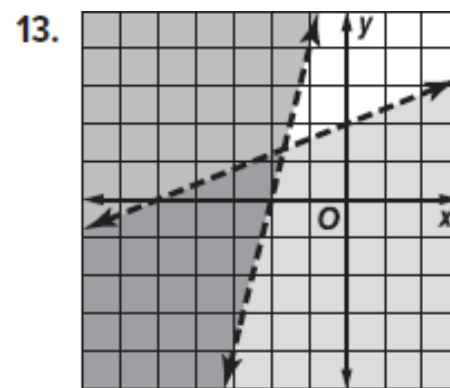

$$14. \begin{cases} 3y - 2x \leq -24 \\ y \geq \frac{2}{3}x - 1 \end{cases}$$

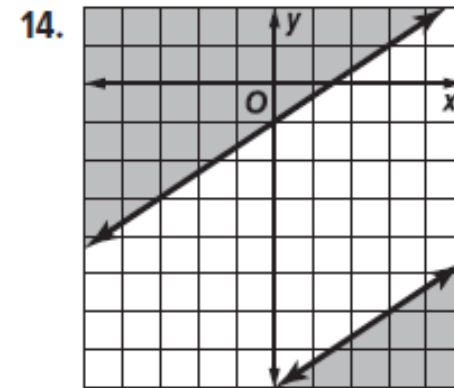

$$15. \begin{cases} y > -\frac{2}{5}x + 2 \\ 5y \leq -2x - 15 \end{cases}$$

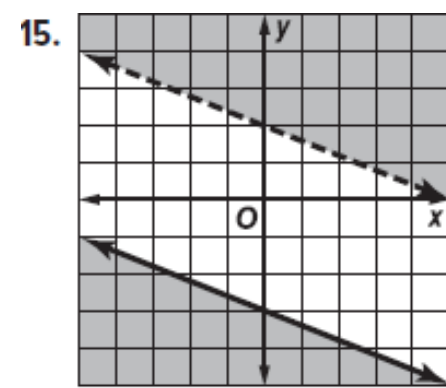

Identify the property of equality of two matrices

Solve each equation.

17.  $[4x \ 3y] = [12 \ -1]$

18.  $[2x \ 3 \ 3z] = [5 \ 3y \ 9]$

19.  $\begin{bmatrix} 4x \\ 5 \end{bmatrix} = \begin{bmatrix} 15 + x \\ 2y - 1 \end{bmatrix}$

20.  $\begin{bmatrix} x + 3y \\ 3x + y \end{bmatrix} = \begin{bmatrix} -13 \\ 1 \end{bmatrix}$

21.  $\begin{bmatrix} 2x + y \\ x - 3y \end{bmatrix} = \begin{bmatrix} 5 \\ 13 \end{bmatrix}$

22.  $\begin{bmatrix} 4x - 3 & 3y \\ 7 & 13 \end{bmatrix} = \begin{bmatrix} 9 & -15 \\ 7 & 2z + 1 \end{bmatrix}$

Multiply, divide, and simplify monomials and expressions involving powers

Simplify. Assume that no variable equals 0. **17.  $-8b^5c^3$**  **16.  $\frac{20x^4}{y^2}$**

$$16. (5x^3y^{-5})(4xy^3)$$

$$17. (-2b^3c)(4b^2c^2)$$

$$18. \frac{a^3n^7}{an^4} a^2n^3$$

$$19. \frac{-y^3z^5}{y^2z^3} -yz^2$$

$$20. \frac{-7x^5y^5z^4}{21x^7y^5z^2} \frac{z^2}{-3x^2}$$

$$21. \frac{9a^7b^5c^5}{18a^5b^9c^3} \frac{a^2c^2}{2b^4}$$

$$22. (n^5)^4 n^{20}$$

$$23. (z^3)^6 z^{18}$$

Use synthetic division to find each quotient.

$$5A. (8x^4 - 4x^2 + x + 4) \div (2x + 1) \quad 5A. 4x^3 - 2x^2 - x + 1 + \frac{3}{2x + 1}$$

$$5B. (8y^5 - 2y^4 - 16y^2 + 4) \div (4y - 1) \quad 5B. 2y^4 - 4y - 1 + \frac{3}{4y - 1}$$

$$5C. (15b^3 + 8b^2 - 21b + 6) \div (5b - 4) \quad 5C. 3b^2 + 4b - 1 + \frac{2}{5b - 4}$$

$$5D. (6c^3 - 17c^2 + 6c + 8) \div (3c - 4) \quad 5D. 2c^2 - 3c - 2$$

Solve polynomial equations by factoring.

Solve each equation.

30.  $x^4 + x^2 - 90 = 0$

30.  $3, -3, \pm i\sqrt{10}$

31.  $x^4 - 16x^2 - 720 = 0$

31.  $6, -6, \pm 2i\sqrt{5}$

32.  $x^4 - 7x^2 - 44 = 0$

32.  $\pm\sqrt{11}, \pm 2i$

33.  $x^4 + 6x^2 - 91 = 0$

33.  $\pm\sqrt{7}, \pm i\sqrt{13}$

34.  $x^3 + 216 = 0$

34.  $-6, 3 \pm 3i\sqrt{3}$

35.  $64x^3 + 1 = 0$

$-\frac{1}{4}, \frac{1 \pm i\sqrt{3}}{8}$



Given a polynomial and one of its factors, find the remaining factors of the polynomial.

17.  $x^3 - 3x + 2; x + 2$   $(x - 1)^2$

18.  $x^4 + 2x^3 - 8x - 16; x + 2$   $x - 2, x^2 + 2x + 4$

19.  $x^3 - x^2 - 10x - 8; x + 2$   $x - 4, x + 1$

20.  $x^3 - x^2 - 5x - 3; x - 3$   $(x + 1)^2$

21.  $2x^3 + 17x^2 + 23x - 42; x - 1$   $21. x + 6, 2x + 7$

22.  $2x^3 + 7x^2 - 53x - 28; x - 4$   $x + 7, 2x + 1$

23.  $x^4 + 2x^3 + 2x^2 - 2x - 3; x - 1$

24.  $x^3 + 2x^2 - x - 2; x + 2$   $x - 1, x + 1$

23.  $x + 1, x^2 + 2x + 3$

Solve each equation. Check your solutions.

23.  $|z - 13| = 21$   $\{34, -8\}$

25.  $9 = |d + 5|$   $\{4, -14\}$

27.  $5|q + 6| = 20$   $\{-2, -10\}$

24.  $|w + 9| = 17$   $\{8, -26\}$

26.  $35 = |x - 6|$   $\{-29, 41\}$

28.  $-3|r + 4| = -21$   $\{3, -11\}$

29.  $3|2a - 4| = 0$  {2}

31.  $2|3x - 4| + 8 = 6$   $\emptyset$

33.  $-3|3t - 2| - 12 = -6$   $\emptyset$

34.  $-5|3z + 8| - 5 = -20$   $\left\{-\frac{5}{3}, -\frac{11}{3}\right\}$

30.  $8|5w - 1| = 0$   $\left\{\frac{1}{5}\right\}$

32.  $4|7y + 2| - 8 = -7$   $\left\{-\frac{1}{4}, -\frac{9}{28}\right\}$

35. **MONEY** The U.S. Mint produces quarters that weigh about 5.67 grams each. After the quarters are produced, a machine weighs them. If the quarter weighs 0.02 gram more or less than the desired weight, the quarter is rejected. Write and solve an equation to find the heaviest and lightest quarters the machine will approve.

$$|x - 5.67| = 0.02;$$

$$\text{heaviest: } 5.69 \text{ g;}$$

$$\text{lightest: } 5.65 \text{ g}$$

Evaluate each expression if  $q = -8$ ,  $r = -6$ , and  $t = 3$ .

$$36. 12 - t|3r + 2| \quad -36$$

$$37. 2q + |2rt + q| \quad 28$$

$$38. -5t - q|8r - t| \quad 393$$

Solve each equation. Check your solutions.

$$39. 8x = 2|6x - 2| \quad \left\{1, \frac{1}{5}\right\}$$

$$40. -6y + 4 = |4y + 12| \quad \left\{-\frac{4}{5}\right\}$$

$$41. 8z + 20 = -|2z + 4| \quad \left\{-\frac{1}{8}\right\}$$

$$42. -3y - 2 = |6y + 25| \quad \left\{-3, -\frac{23}{3}\right\}$$

Write an equation of a line given the slope and a point on the line

**PERSEVERANCE** Write an equation in slope-intercept form for the line that satisfies each set of conditions.

23. passes through  $(4, 2)$ , perpendicular to  $y = -2x + 3$   $y = \frac{1}{2}x$

25. passes through  $(12, 0)$ , parallel to  $y = -\frac{1}{2}x - 3$   $y = -\frac{1}{2}x + 6$

27. **FINANCIAL LITERACY** Julio buys a used car for \$5900. Monthly expenses for the car—which include insurance, maintenance, and gas—average \$180 per month. Write an equation that represents the total cost of buying and owning the car for  $x$  months.

27.  $y = 180x + 5900$

24. passes through  $(-6, -6)$ , parallel to  $y = \frac{4}{3}x + 8$   $y = \frac{4}{3}x + 2$

26. passes through  $(10, 2)$ , perpendicular to  $y = 4x + 6$   $y = -0.25x + 4.5$

## Identify and use parent functions

Describe the translation in each function. Then graph the function.

14.  $y = x^2 + 4$

14. translation of the graph of  $y = x^2$  up 4 units

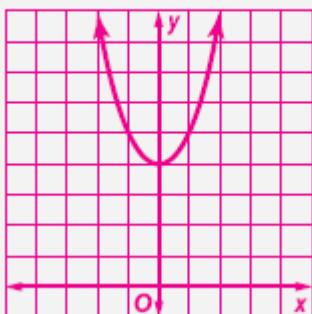

15.  $y = |x| - 3$

15. translation of the graph of  $y = |x|$  down 3 units

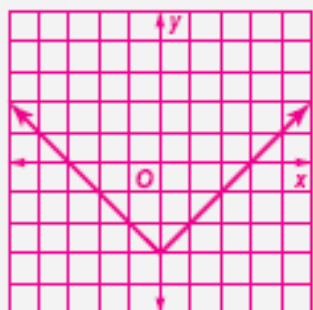

16.  $y = x - 1$

16. translation of the graph of  $y = x$  down 1 unit or right 1 unit

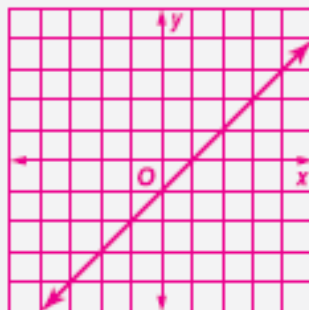

17.  $y = x + 2$

17. translation of the graph of  $y = x$  up 2 units or left 2 units

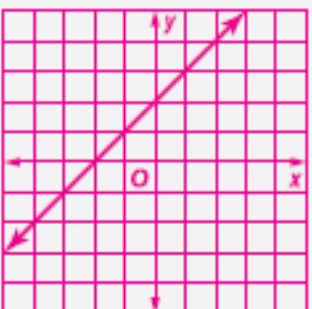

18.  $y = (x - 5)^2$

18. translation of the graph of  $y = x^2$  right 5 units



19.  $y = |x + 6|$

19. translation of the graph of  $y = |x|$  left 6 units

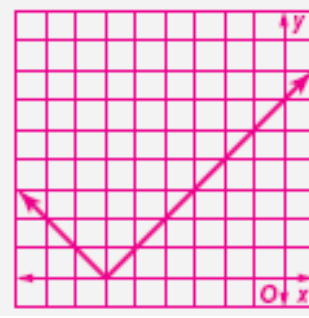

## Identify and use parent functions

Describe the reflection in each function. Then graph the function.

20.  $y = -x$

20. reflection of the graph of  $y = x$  across the  $x$ -axis

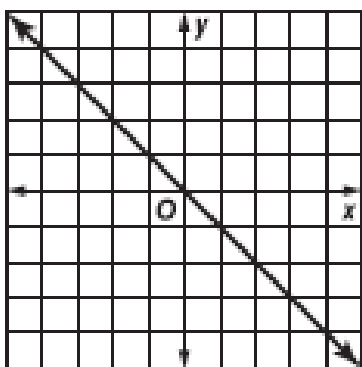

21.  $y = -x^2$

21. reflection of the graph of  $y = x^2$  across the  $x$ -axis

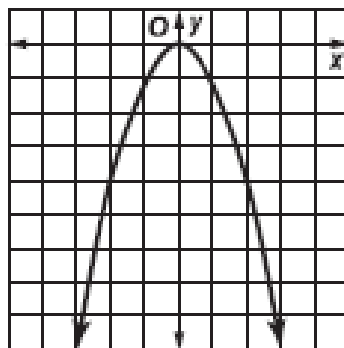

22.  $y = (-x)^2$

22. reflection of the graph of  $y = x^2$  across the  $y$ -axis

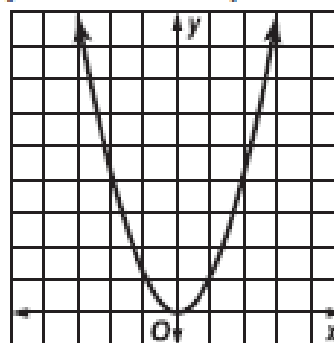

23.  $y = |-x|$

23. reflection of the graph of  $y = |x|$  across the  $y$ -axis

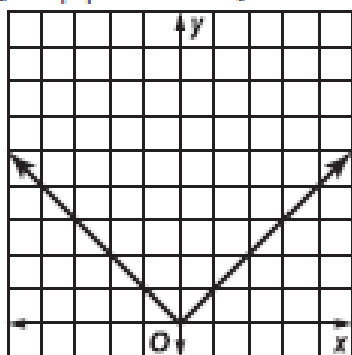

24.  $y = -|x|$

24. reflection of the graph of  $y = |x|$  across the  $x$ -axis

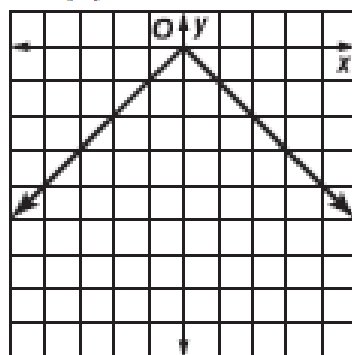

25.  $y = (-x)$

25. reflection of the graph of  $y = x$  across the  $y$ -axis

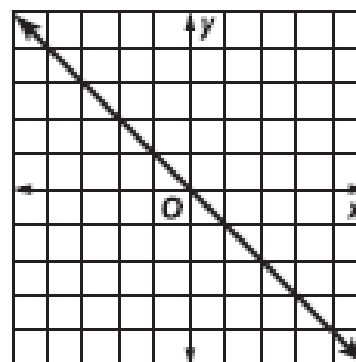

## Identify and use parent functions

Describe the dilation in each function. Then graph the function.

26.  $y = (3x)^2$

26. horizontal compression of the graph of  $y = x^2$

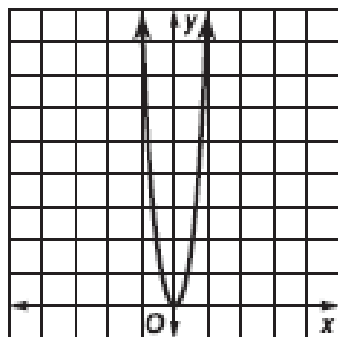

27.  $y = 6x$

27. vertical expansion of the graph of  $y = x$ ; The slope is steeper than that of  $y = x$ .

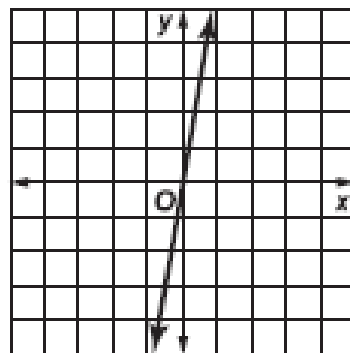

28.  $y = 4|x|$

28. The dilation stretches the graph of  $y = |x|$  vertically.

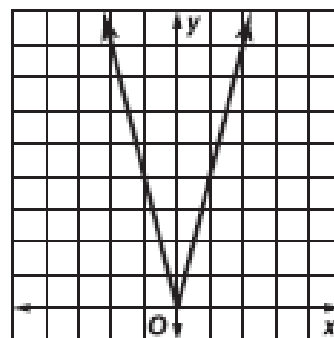

29.  $y = |2x|$

29. The dilation compresses the graph of  $y = |x|$  horizontally.

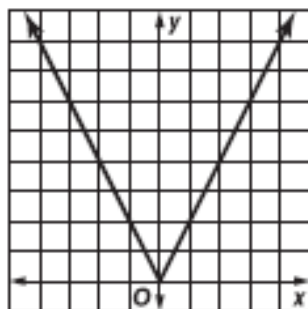

30.  $y = \frac{2}{3}x$

30. The dilation compresses the graph of  $y = x$  vertically; the slope is not as steep as that of  $y = x$ .

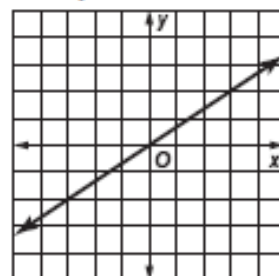

31.  $y = \frac{1}{2}x^2$

31. vertical compression of the graph of  $y = x^2$

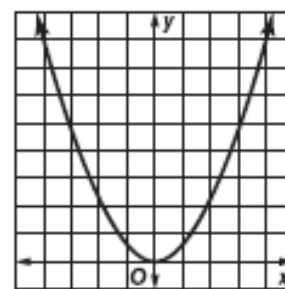



**Example 4** Multi-Step Operations

If  $A = \begin{bmatrix} -9 & 12 \\ 2 & -6 \end{bmatrix}$  and  $B = \begin{bmatrix} -4 & -8 \\ 2 & -3 \end{bmatrix}$ , find  $-4B - 3A$ .

$$\begin{aligned} -4B - 3A &= -4 \begin{bmatrix} -4 & -8 \\ 2 & -3 \end{bmatrix} - 3 \begin{bmatrix} -9 & 12 \\ 2 & -6 \end{bmatrix} \\ &= \begin{bmatrix} -4(-4) & -4(-8) \\ -4(2) & -4(-3) \end{bmatrix} - \begin{bmatrix} 3(-9) & 3(12) \\ 3(2) & 3(-6) \end{bmatrix} \\ &= \begin{bmatrix} 16 & 32 \\ -8 & 12 \end{bmatrix} - \begin{bmatrix} -27 & 36 \\ 6 & -18 \end{bmatrix} \\ &= \begin{bmatrix} 16 - (-27) & 32 - 36 \\ -8 - 6 & 12 - (-18) \end{bmatrix} \\ &= \begin{bmatrix} 43 & -4 \\ -14 & 30 \end{bmatrix} \end{aligned}$$

**Guided Practice**

4. If  $A = \begin{bmatrix} -5 & 3 \\ 6 & -8 \\ 2 & 9 \end{bmatrix}$  and  $B = \begin{bmatrix} 12 & 5 \\ 5 & -4 \\ 4 & -7 \end{bmatrix}$ , find  $-6B + 7A$ .

19	Perform algebraic operations with matrices إجراء عمليات جبرية على المصفوفات	Example 4	P172
	Multiply matrices ضرب المصفوفات	Exercises (4-11)	P181

Find each product, if possible.

$$4. \begin{bmatrix} 2 & 1 \\ 7 & -5 \end{bmatrix} \cdot \begin{bmatrix} -6 & 3 \\ -2 & -4 \end{bmatrix}$$

$$5. \begin{bmatrix} 10 & -2 \\ -7 & 3 \end{bmatrix} \cdot \begin{bmatrix} 1 & 4 \\ 5 & -2 \end{bmatrix}$$

$$6. [9 \quad -2] \cdot \begin{bmatrix} -2 & 4 \\ 6 & -7 \end{bmatrix}$$

$$7. \begin{bmatrix} -9 \\ 6 \end{bmatrix} \cdot [-1 \quad -10 \quad 1]$$

$$8. \begin{bmatrix} -8 & 7 & 4 \\ -5 & -3 & 8 \end{bmatrix} \cdot \begin{bmatrix} 10 & 6 \\ 8 & 4 \end{bmatrix}$$

$$9. \begin{bmatrix} 2 & 8 \\ 3 & -1 \end{bmatrix} \cdot \begin{bmatrix} 6 \\ -7 \end{bmatrix}$$

$$10. \begin{bmatrix} -4 & 3 & 2 \\ -1 & -5 & 4 \end{bmatrix} \cdot \begin{bmatrix} 2 & 1 & 6 \\ 8 & 4 & -1 \\ 5 & 3 & -2 \end{bmatrix}$$

$$11. \begin{bmatrix} 2 & 5 & 3 & -1 \\ -3 & 1 & 8 & -3 \end{bmatrix} \cdot \begin{bmatrix} 6 & -3 \\ -7 & 1 \\ 2 & 0 \\ -1 & 0 \end{bmatrix}$$

Identify general shapes of graphs of polynomial functions.

Complete each of the following.

- Estimate the  $x$ -coordinate of every turning point and determine if those coordinates are relative maxima or relative minima.
- Estimate the  $x$ -coordinate of every zero.
- Determine the smallest possible degree of the function.
- Determine the domain and range of the function.

34.

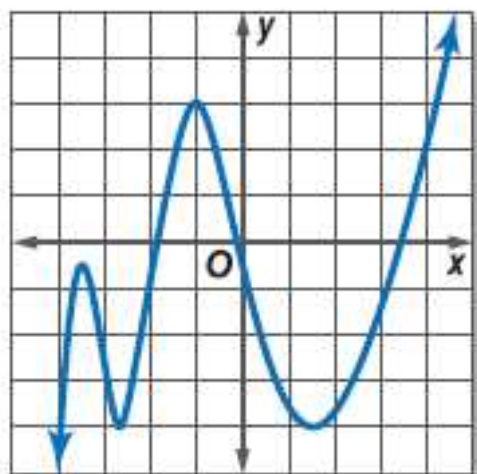

35.

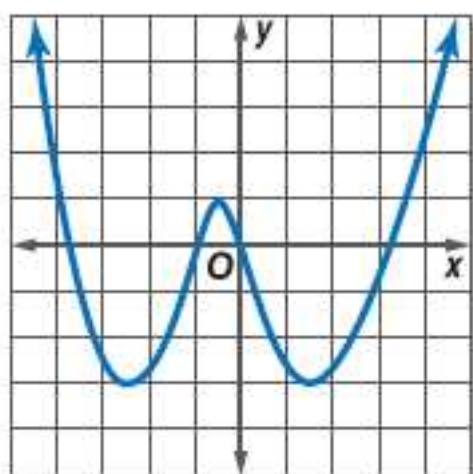

36.

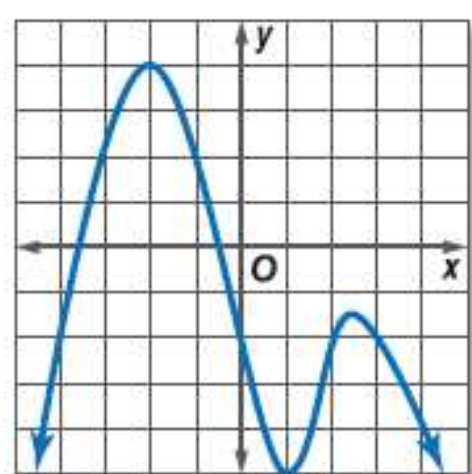

Identify general shapes of graphs of polynomial functions.

Complete each of the following.

- Estimate the  $x$ -coordinate of every turning point and determine if those coordinates are relative maxima or relative minima.
- Estimate the  $x$ -coordinate of every zero.
- Determine the smallest possible degree of the function.
- Determine the domain and range of the function.

37.

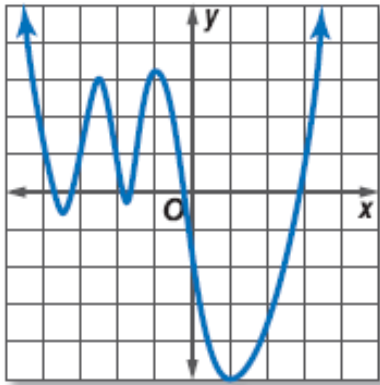

38.

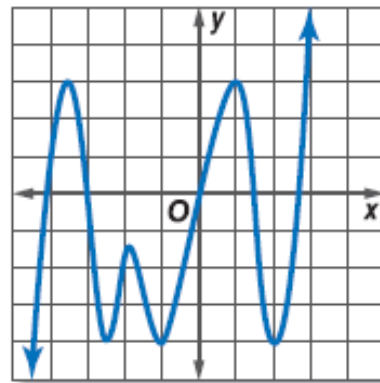

39.

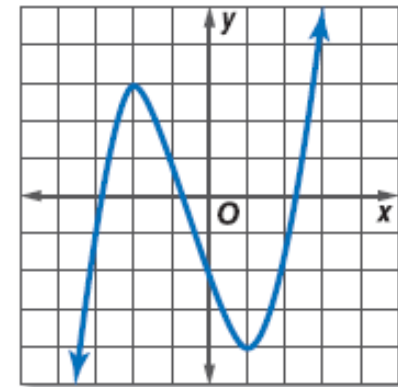

Solve polynomial equations by factoring.

### Real-World Example 4 Solve Polynomial Functions by Factoring

**GEOMETRY** Refer to the beginning of the lesson.

If the small cube is half the length of the larger cube and the figure is 7000 cubic centimeters, what should be the dimensions of the cubes?

Since the length of the smaller cube is half the length of the larger cube, then their lengths can be represented by  $x$  and  $2x$ , respectively. The volume of the object equals the volume of the larger cube minus the volume of the smaller cube.

$$(2x)^3 - x^3 = 7000$$

$$8x^3 - x^3 = 7000$$

$$7x^3 = 7000$$

$$x^3 = 1000$$

$$x^3 - 1000 = 0$$

$$(x - 10)(x^2 + 10x + 100) = 0$$

$$x - 10 = 0 \quad \text{or} \quad x^2 + 10x + 100 = 0$$

$$x = 10$$

$$x = -5 \pm 5i\sqrt{3}$$

Since 10 is the only real solution, the lengths of the cubes are 10 cm and 20 cm.

### Guided Practice

4. Determine the dimensions of the cubes if the length of the smaller cube is one third of the length of the larger cube, and the volume of the object is 3250 cubic centimeters. **5 cm and 15 cm**

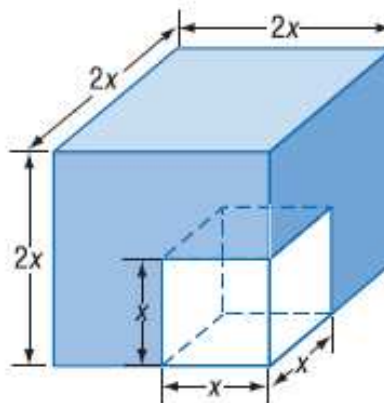

A small cube is cut out of a larger cube. The volume of the remaining figure is given and the dimensions of each cube need to be determined.

This can be accomplished by factoring the cubic polynomial  $x^3 - y^3$ .

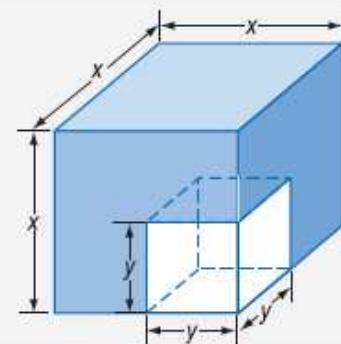

57. **GEOMETRY** The volume of the figure at the right is 440 cubic centimeters. Find the value of  $x$  and the length, height, and width.  $x = 8; 5, 8, 11$

